

AWS Structural Welder Qualification Test

National Certification

Test #: D1-SM-F4-P-A-U

SMAW - E7018

1" Unlimited Thickness Test (Two positions: 3G - vertical & 4G - overhead)

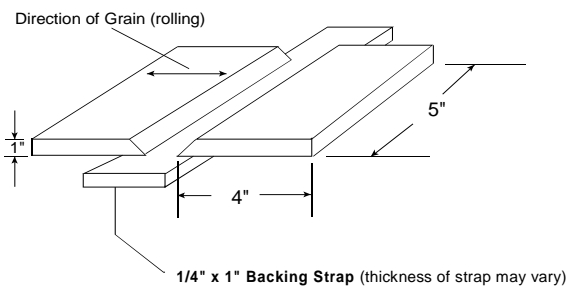
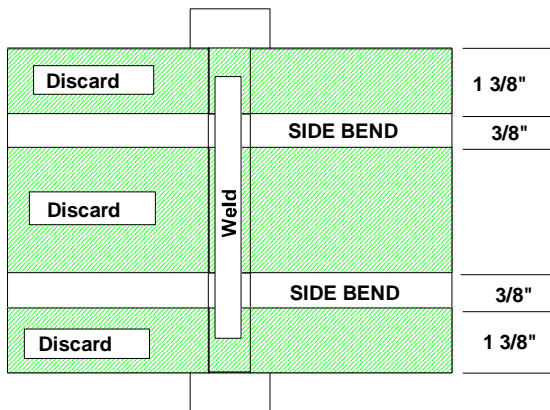

- Fill shall consist of stringer beads, the number of beads and placement shown is approximate. (Stringer bead width shall be 2 to 3 times the diameter of the electrode).
Example: 1/8" E7018, maximum bead width=3/8"
- Root pass may be done with 3/32" or 1/8" E7018 electrode.
- Fill and cover passes may be done with 1/8 or 5/32" E7018 electrode.
- Grinding allowed (except on cover passes)
- 1 hour and 30 minute time limit per position.

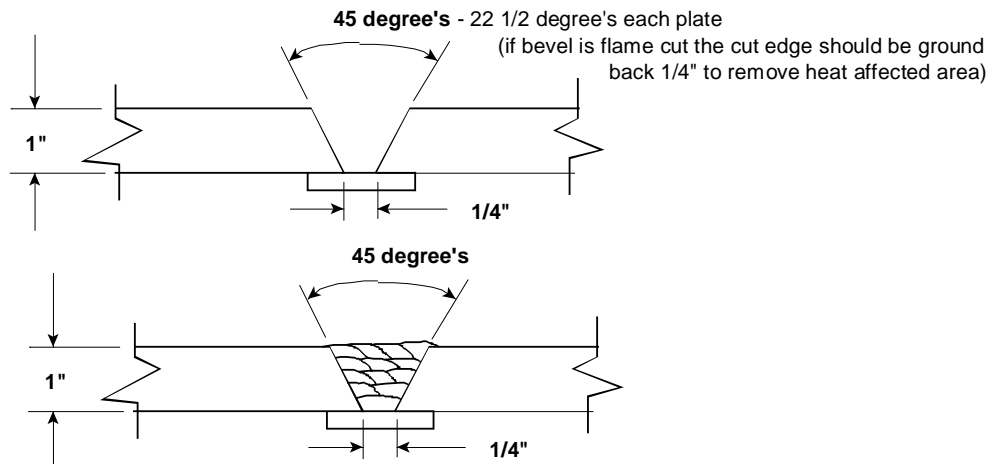

Bead placement is an approximation