

AWS Structural Welder Qualification Test

"AWS QC7" National Certification Program

Test #: G-D1.1-FCAW-P-A-L

Flux-Cored Arc Welding (FCAW): E71T-1

3/8" Limited Thickness Test (Two positions: 3G-vertical & 4G-overhead)

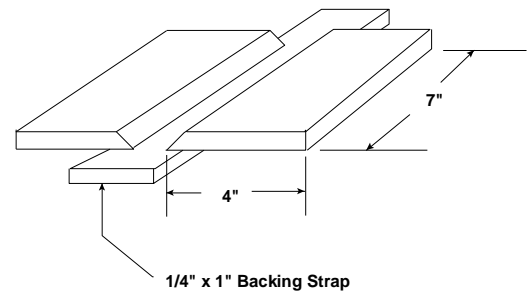
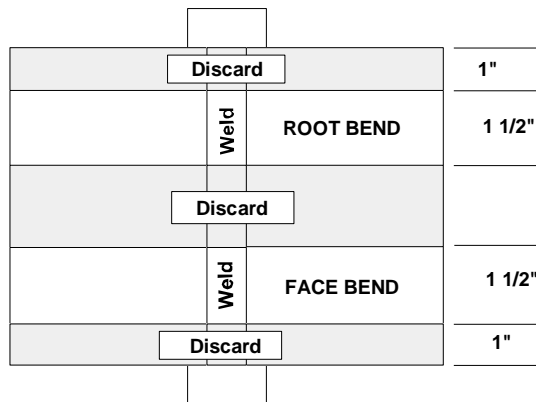

- Fill shall consist of stringer beads.
Maximum bead width=3/4"
- Electrode used is E71T-1, 045" diameter with 75% argon / 25% CO² shielding gas.
- Grinding / power tools allowed except on cover passes.
- 45 minute time limit per position.

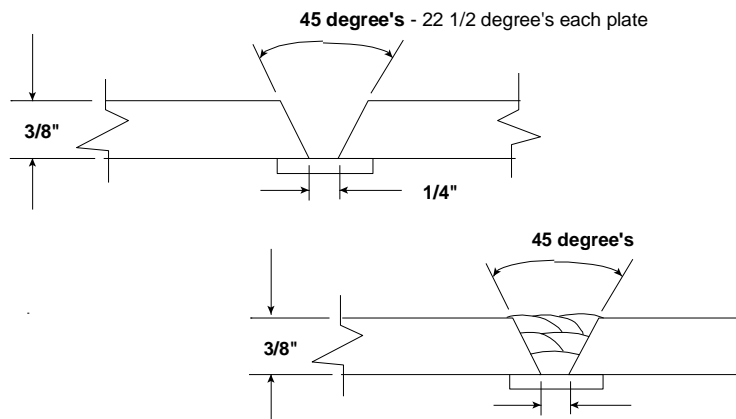

Bead placement is an approximation